



DEPARTMENT FOR TRANSPORT



REGISTER OF BRITISH SHIPS PART III (SMALL SHIPS REGISTER)

APPLICATION FOR FIRST REGISTRATION OR RE-REGISTRATION

FOR OFFICIAL USE ONLY

Please read the attached guidance notes and refer to them when completing this form. PLEASE USE CAPITAL LETTERS AND TICK BOXES AS APPROPRIATE

DETAILS OF SHIP

1. Name of Ship _____ **SEE NOTE 7**
(Please note that ships bearing undesirable names will not be allowed onto the register).
(Please tick one box only)

2. Description Sailing Yacht Motor Yacht Dinghy

 Motor Sailer Inflatable Sports Boat Barge **SEE NOTE 9**

 Narrow Boat Wet Bike Hovercraft Other (Please specify fully in the space below)

3. Class name or make (if known) _____

4. Overall length in metres to the nearest centimetre **SEE NOTE 8**
(Please write length in words _____ metres _____ centimetres)

5. Number of hulls 5(a) Hull Identification No. (HIN)

6. Is the ship registered under Part I of the Register of British Ships? YES NO
SEE NOTE 5

7. Has the ship ever been registered on the Small Ships Register? YES NO
If NO, please proceed to question 10.

8. Please state the SSR number and date of expiry of the Certificate of Registration
(The number should be permanently marked on or affixed to the ship).

SSR _____ Date of Expiry (if known) _____

9. Are you the owner recorded on the Certificate of Registration? YES NO

If NO, when did you acquire the ship? Date _____

DETAILS OF PRESENT OWNER

10. Total number of PRESENT owners

Please enter the name and address where ordinarily resident and the nationality of every present owner (not previous). The person signing this form should appear first. It is this person to whom all correspondence in connection with Small Ships Registration will be sent. For more than two owners, please provide their details on a separate sheet for questions 11 – 13.

SEE
NOTES
3 & 4

11. Surname _____

Forenames _____

Title Mr Mrs Miss

Other (please state) _____

Address _____

Postcode _____

Daytime Telephone Number _____

12. Nationality _____ SEE NOTE 3

13. If an EU or EEA citizen are you established within the meaning of Articles 48 and 52 of the EU treaty

YES NO

11. Surname _____

Forenames _____

Title Mr Mrs Miss

Other (please state) _____

Address _____

Postcode _____

Daytime Telephone Number _____

12. Nationality _____ SEE NOTE 3

13. If an EU or EEA citizen are you established within the meaning of Articles 48 and 52 of the EU treaty

YES NO

DECLARATION

If the ship is jointly owned, the declaration should be signed by the person whose details appear first in the ownership section.

I UNDERSTAND THAT IT IS AN OFFENCE TO KNOWINGLY OR RECKLESSLY MAKE A FALSE STATEMENT IN ORDER TO OBTAIN REGISTRATION AND HEREBY DECLARE THAT, TO THE BEST OF MY KNOWLEDGE, THE DETAILS GIVEN IN THIS APPLICATION FORM ARE CORRECT.

Signed _____ Date _____

Name (CAPITAL LETTERS) _____

Statement of length (Required only where the overall length exceeds 24 metres – see 2nd paragraph of note 8)

I CERTIFY THAT THE SHIP DESCRIBED IN THIS APPLICATION IS LESS THAN 24 METRES IN LENGTH WHEN MEASURED IN ACCORDANCE WITH THE FORMULA CONTAINED IN THE INTERNATIONAL CONVENTION ON TONNAGE MEASUREMENT OF SHIPS 1969 AND GIVEN EFFECT IN THE UNITED KINGDOM BY THE MERCHANT SHIPPING (TONNAGE) REGULATIONS 1997 (SI 1997/No.1510).

Signed _____ Date _____

Name (CAPITAL LETTERS) _____

Title _____

Please send this completed form together with any enclosure needed to:-

Small Ships Register

Registry of Shipping and Seamen

PO BOX 420, CARDIFF, CF24 5XR.

Cheques and Postal Order should be made payable to the MCA. (please print name of vessel on reverse of cheque and SSR No if it is an application to renew). **PLEASE DO NOT SEND CASH.**

**Notes for Guidance
(To be retained by the applicant)**

1. What is Part III of the Register?

Part III (commonly called the Small Ships Register – SSR) is for ships, which want only simple registration; it does not register ‘title’ and you cannot register mortgages on this part of the Register.

It provides an inexpensive, simple registration, which proves the ship’s nationality (a kind of passport). A Part III certificate may not be accepted in some foreign ports if you are using your ship for ‘commercial purposes’; eg diving or chartering.

2. What is a small ship?

A small ship is one, which is less than 24 metres (79 feet), in overall length.

The following ships cannot be registered on Part III

- those owned by a company
- those over 24 metres in length
- fishing or submersible vessels

3. Who may register a small ship?

A small ship may be registered if it is owned by one or more of the following persons who are ordinarily resident in the UK:-

- (a) British Citizens
- (b) Persons who are nationals of a European Union or Economic Area country other than the United Kingdom and are established* in the UK
- (c) British Dependant Territories citizens; British Overseas citizens; persons who under the British Nationality Act 1991 and are British subjects; persons who under the Hong Kong (British Nationality) Order are British Nationals Overseas, and
- (d) Commonwealth citizens not falling within those paragraphs.

* Established – It is not sufficient to live in the UK to be ‘established’ in accordance with Articles 48 and 52 of the EU Treaty. To be ‘established’ a person must make an economic contribution to the UK by being the proprietor of a business, being employed, or having very recently retired from such employment, ie within the last 6 months. If you have any doubts about your ‘establishment’ you should consult the Registry.

4. What does ‘ordinarily resident’ mean?

For the purposes of registering a ship it means living and sleeping in the UK for a significant part of the year. A person may be considered to be ordinarily resident in the country in which they live for a period of, or periods which collectively amount to 185 days or more in a twelve month period. If you are resident in the UK for tax purposes, you will generally be regarded as resident for the purpose of registration.

5. Can my ship be registered on Part I and Part III?

Ships cannot be on more than one part of the Register at any one time. If you have Part I registration it is to your advantage to keep your ship registered on that Part rather than transfer it to the SSR. If you wish to transfer from one Part of the Register to another, it will be necessary to close the ship’s current registration before the transfer can be made.

Further information can be obtained from:-

Small Ships Register
Register of Shipping & Seamen
PO BOX 420
CARDIFF CF24 5XR
Tel: 029 20448800

6. How long does SSR registration last?

Registration on Part III of the Register lasts for 5 years. The date of expiry shows on the ship’s certificate of registry. You may apply to renew the ship’s registration up to 3 months before the certificate expires. Registration ceases immediately if a ship is sold or any details change which appear on the certificate of registry. Where this happens the registered owner must return the certificate with a brief explanation of the circumstances of any change. You must also notify the Registry of any change of address.

7. Ship Names

Ships will not be registered if they have undesirable or offensive names or which might cause confusion; eg if prefixed by FV or HMS. Names such as 'SOS', 'MAYDAY' or 'LIFEBOAT' will not be allowed. Ships must have a name before they can be registered.

8. Measuring the Ship

In most cases owners may measure the overall length of the ship themselves (see question 4 on the application form). 'Overall length' is the distance between the foreside of the foremost fixed structure and the aftside of the aftermost permanently fixed structure of the ship. The diagrams below show between which points on most ships the measurements should be made. On multi-hulled craft, the longest hull should be measured. If you are in difficulty or require advice on measuring craft of novel design, you may seek assistance from the Royal Yachting Association at: RYA House, Romsey Road, Eastleigh, SO50 9YA.

Where the ship is found to be 24 metres or a little more in overall length, it may still qualify for entry onto the Small Ships Register. You must have the Statement of Length at the end of the application form signed by a qualified naval architect or ships surveyor stating that the ship is less than 24 metres in length when measured in accordance with the formula contained in the Convention on Tonnage Measurements of Ships, 1969.

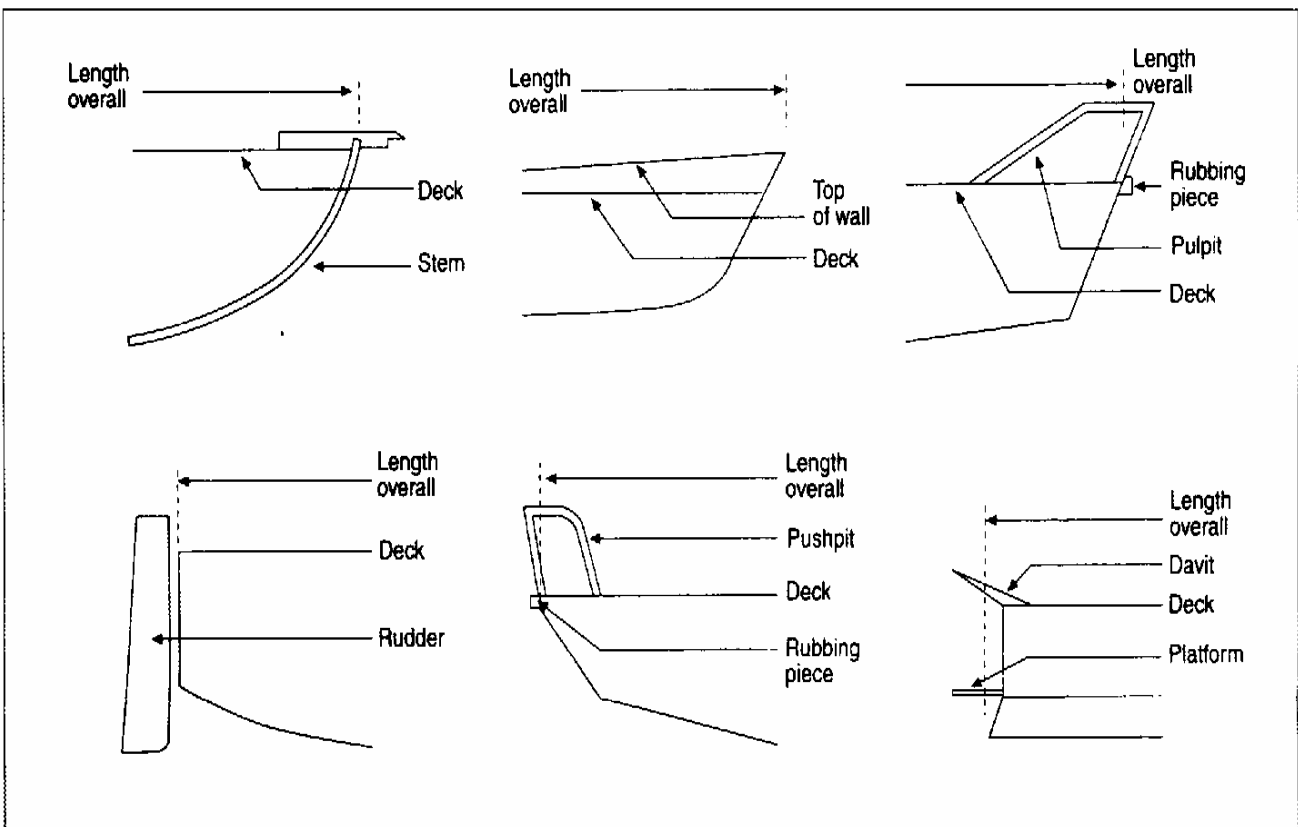

9. Definitions

- Sailing Yacht - boat primarily propelled by sails (larger than a dinghy) with a fixed keel or cabin
- Motor Yacht - large boat largely propelled with an engine either steam or internal combustion including cabin cruisers
- Dinghy - all types of dinghy including rowboats and small sailing vessels without a fixed keel or cabin
- Motor Sailer - boat propelled by engine or sails with a keel and cabin
- Inflatable - including rigid and non-rigid types
- Sportsboat - including powerboats and launches
- Barge - all types including houseboats
- Narrow Boat - vessel built specifically for use within narrow lock systems
- Wet Bike - including jet skis, etc
- Hovercraft - vessel supported by an air cushion
- Other Vessel Type - anything which does not easily fit into the above types